

## Rapid Dump Valve

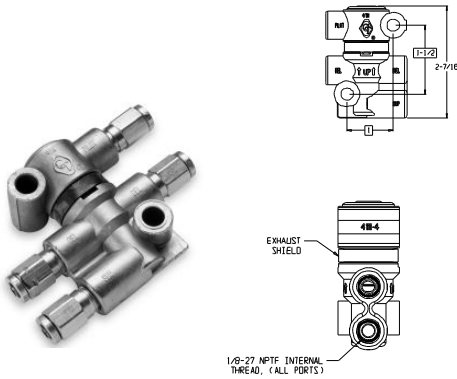

The Rapid Dump Valve is a pilot-operated, normally open, three-way valve with two delivery ports. It is intended to be chassis-mounted on heavy-duty, on-highway vehicles with air-ride suspensions. Its function is to remotely deflate the air ride suspension's air bags. This valve can also be used to open and close lift and tail gates.

Typical supply pressure is equal to bag pressure (5 - 60 PSIG) when Rapid Dump Valve is not actuated and raises the system pressure (90-120 PSIG) when Rapid Dump Valve is actuated. Typical pilot pressure is 90-120 PSIG.

### Performance

Application	Remotely deflates the air-ride suspension's air bags. This valve can also be used to open and close lift and tail gates.
Material	Die cast zinc construction.
Part Number	4111-X
Rated PSI	90–120 PSIG
Operating Temperature	-40°F to 180°F (-40°C to 82.2°C)
Allowed Leakage	<p><b>Normally-Open Condition (not actuated)</b></p> <p>A) The Rapid Dump Valve shall not leak in excess of 10 SCCM with any pressure from zero to 120 PSIG applied to supply (SUP) port and delivery ports blocked when pilot port is open to atmosphere.</p> <p><b>Pilot Condition (actuated)</b></p> <p>A) The Rapid Dump Valve shall not leak in excess of 50 SCCM with any pressure from 80 to 120 PSIG applied to pilot port.</p> <p>B) The Rapid Dump Valve shall not leak in excess of 50 SCCM with any pressure from zero to 120 PSIG applied to supply port and delivery ports open.</p>
Proof Pressure	A) 300 PSIG pressure applied for 10 seconds to supply port with delivery ports blocked and pilot port open to atmosphere.

## Rapid Dump Valve



### Drawings

